

# ANEXO "A"

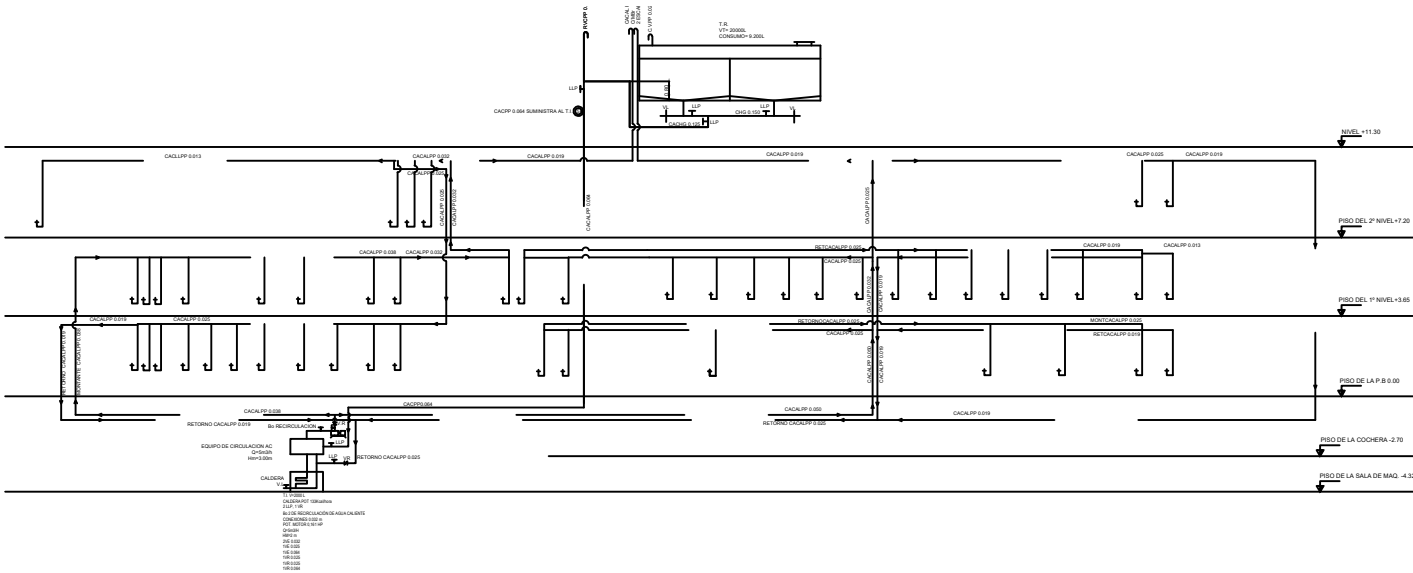

# AGUA CALIENTE

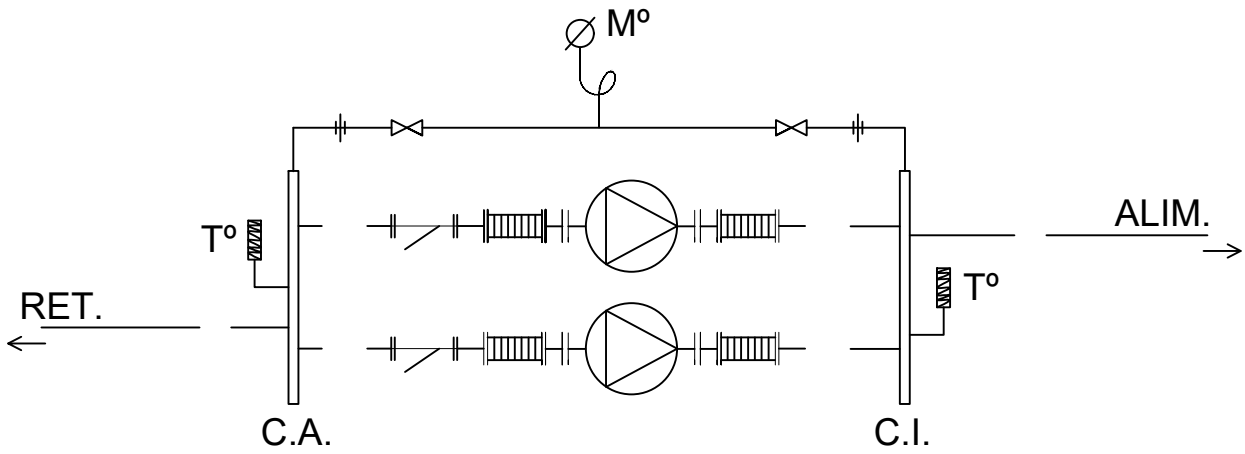

DETALLE CONEXION ELECTROBOMBAS

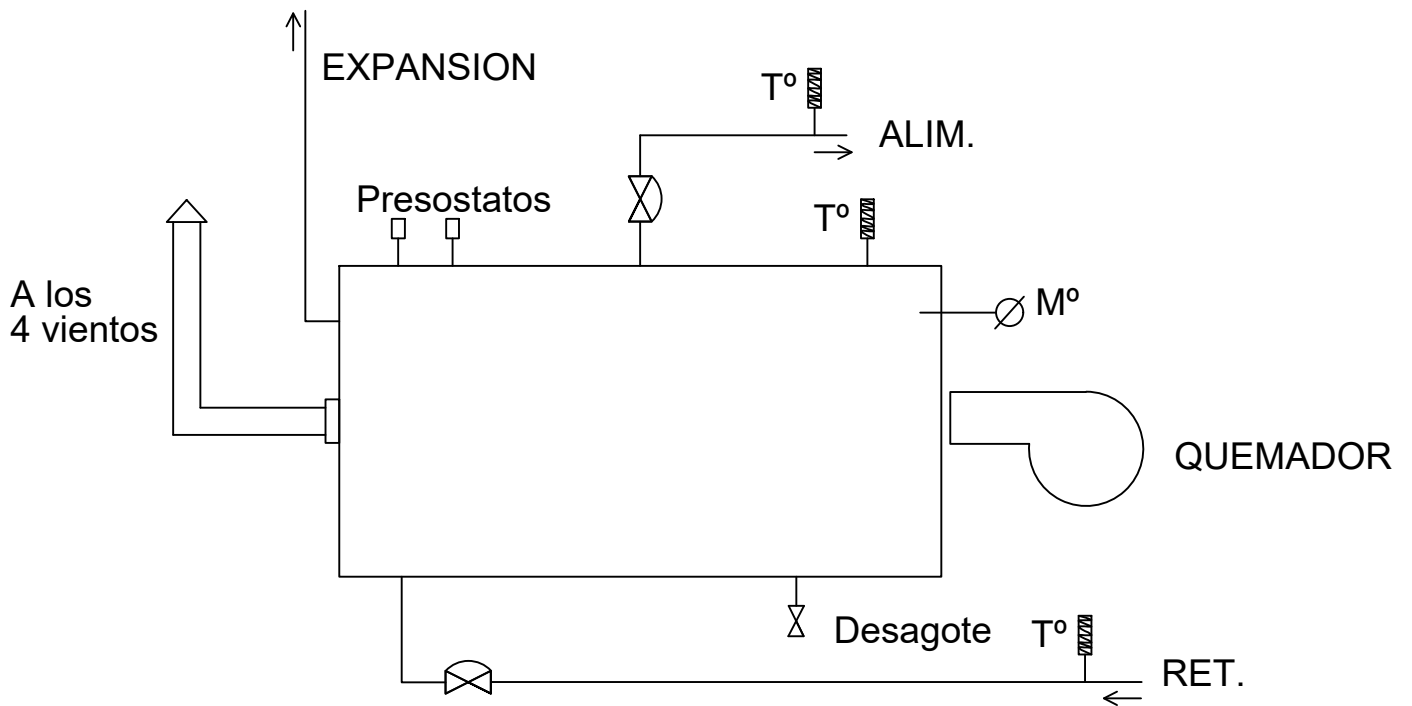

DETALLE CONEXION CALDERAS

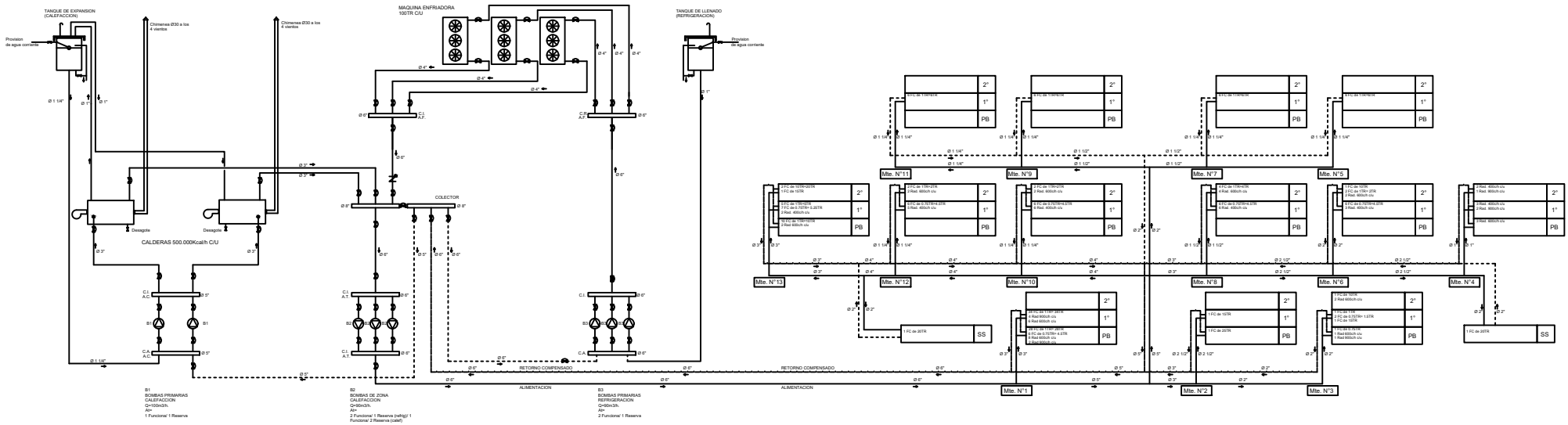

B1 BOMBAS PRIMARIAS CALEFACCION  
Ø=150mm/h  
AV  
1 Funcional 1 Reserva

B2 BOMBAS DE ZONA CALEFACCION  
Ø=50mm/h  
AV  
2 Funcional 1 Reserva (ø=60) 1 Funcional 2 Reserva (ø=60)

B3 BOMBAS PRIMARIAS REFRIGERACION  
Ø=150mm/h  
AV  
2 Funcional 1 Reserva

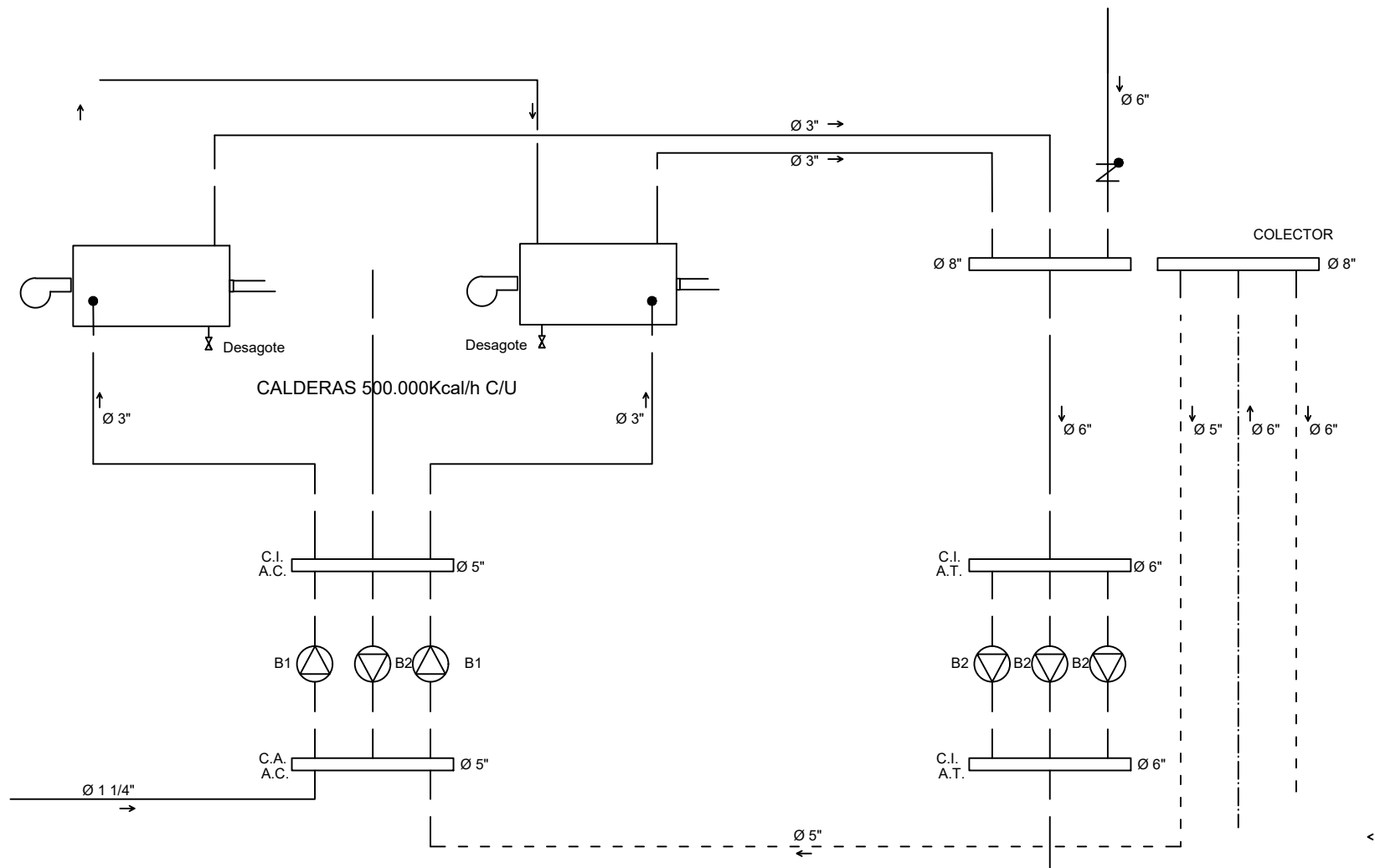

B1  
 BOMBAS PRIMARIAS  
 CALEFACCION  
 Q=100m<sup>3</sup>/h.  
 At=  
 1 Funciona/ 1 Reserva

B2  
 BOMBAS DE ZONA  
 CALEFACCION  
 Q=90m<sup>3</sup>/h.  
 At=  
 2 Funciona/ 1 Reserva (refrig)/ 1  
 Funciona/ 2 Reserva (calef)

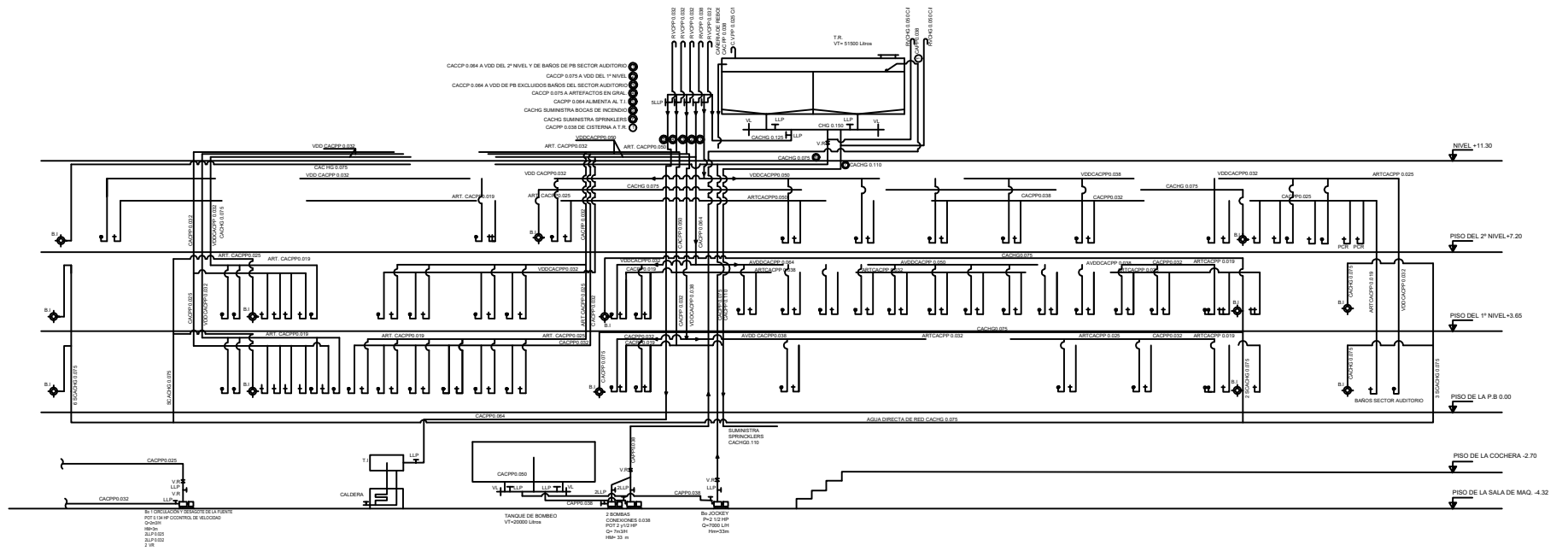

# AGUA FRIA

ANEXO "A"

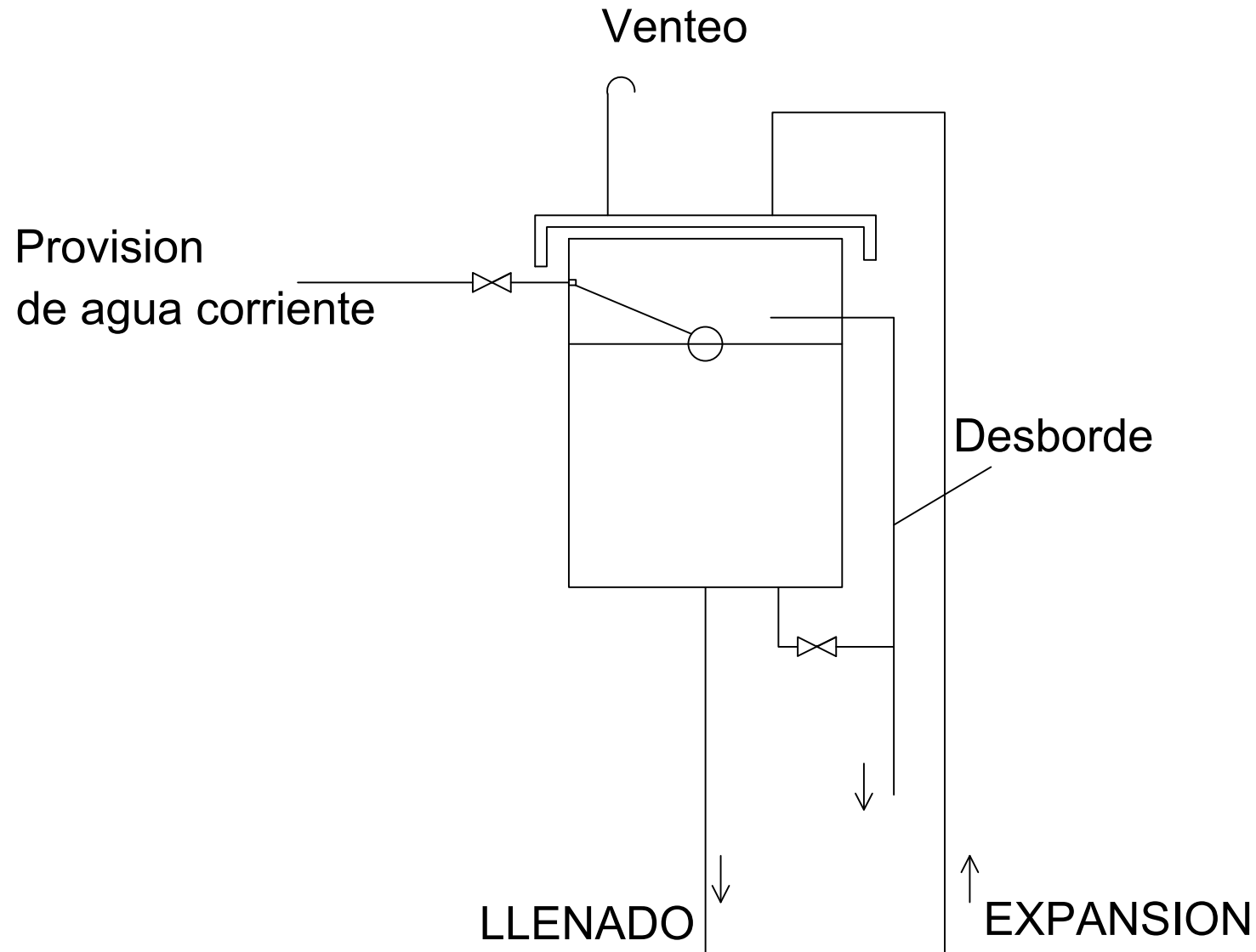

DETALLE CONEXION TANQUE DE EXP.

# ANEXO "A"

